

AH0608T Series Air Cooler

Symbol

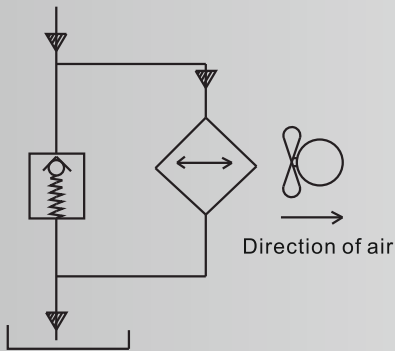

Performance curve

$kr(\frac{kcal}{h^{\circ}C})$

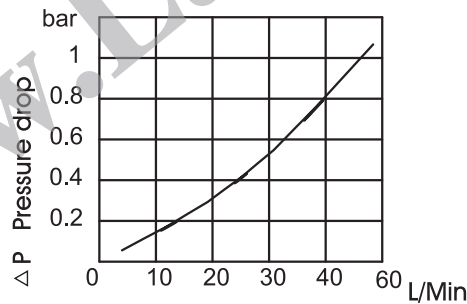
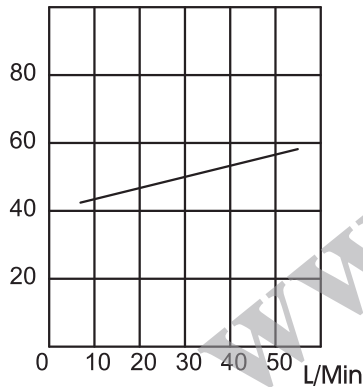

Technical data

Model	Voltage	Max. flow rate (l/min)	Max. working pressure (bar)	Consumed power (W)	Speed (rpm)	Noise (db)	Weight (kg)
AH0608T	DC12V	60	35	18	2500	50	4.3
	DC24V						
	AC110V (50Hz/60Hz)			38	2620		
	AC220V (50Hz/60Hz)						
	AC380V (50Hz/60Hz)						

AH0608T series air cooler dimensions

Unit: mm

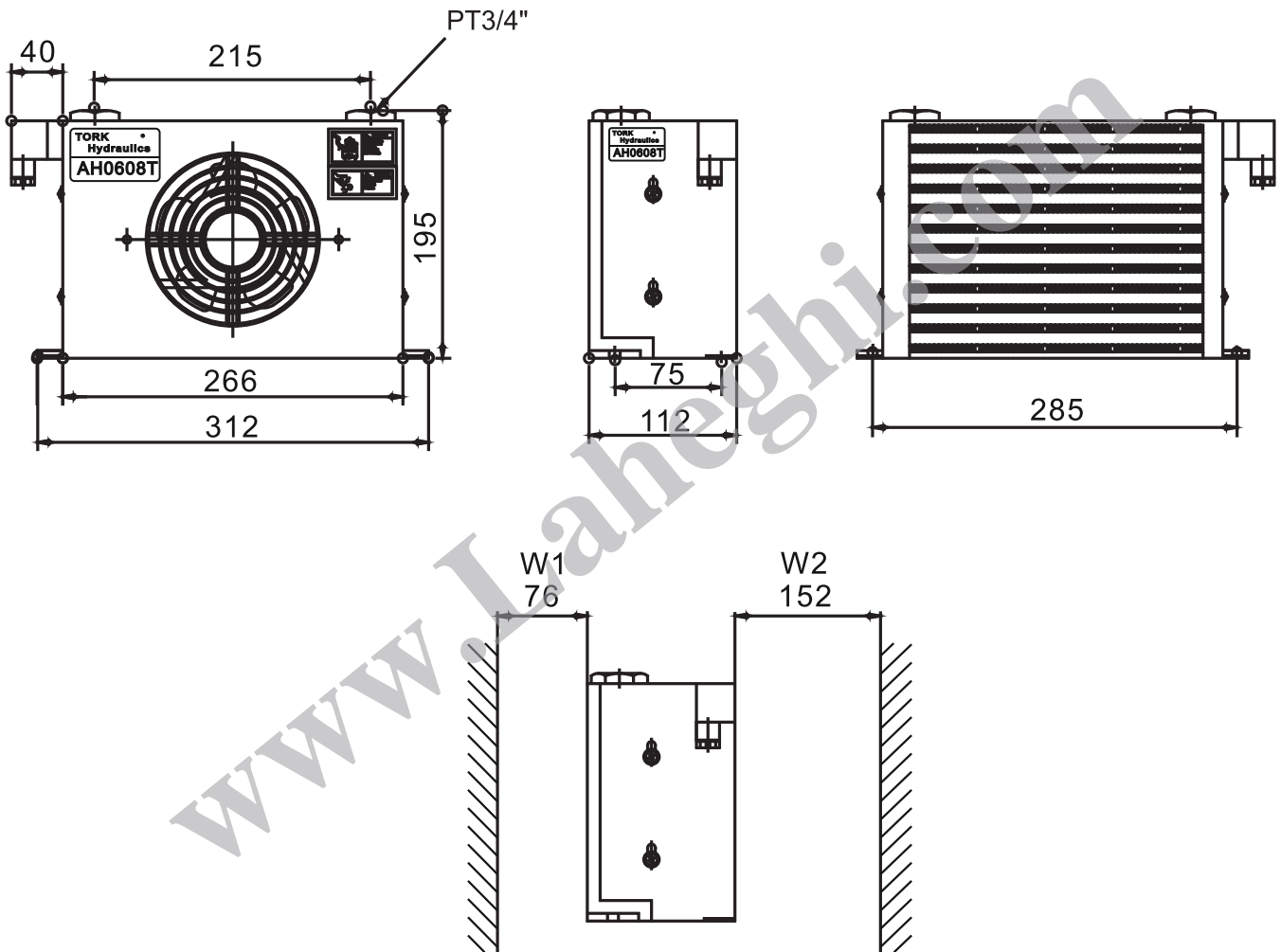

W1 is the min. distance between air inlet and obstacle

W2 is the min. distance between air outlet and obstacle